

If you have the original box:

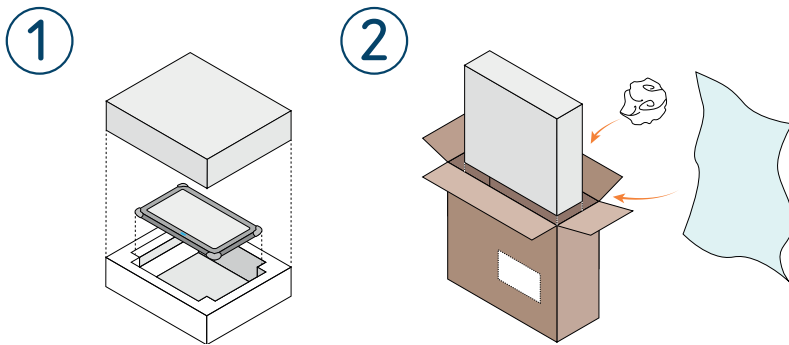

1. Place your device, along with any power leads and cables back into the original box.

2. Pack the box into a second box, with soft packaging (eg. scrunched paper, bubble wrap, polystyrene chips) to prevent movement.

If you do not have the original box:

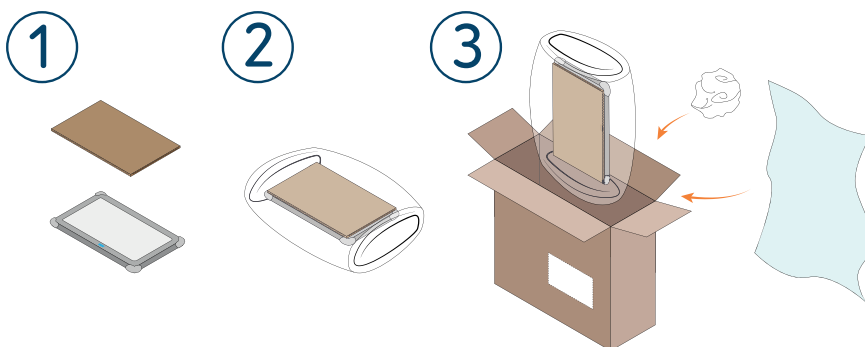

1. Cover your device's screen with a protective layer eg. cardboard.

2. Wrap your device with soft packing, eg bubble wrap. A total thickness of 2 inches is recommended.

3. Pack your wrapped device into a mailing box with soft packaging surrounding to prevent movement.

Once packed, cut out and affix the label below to your box. Write the RMA number in the box provided. Your device is now ready for collection. Any questions or queries please contact us: 01684 578868 / repairs@thinksmartbox.com

Smartbox

Repairs and Service

Smart Works
Barnards Green
Malvern
WR14 3NB

RMA Number:

thinksmartbox.com | repairs@thinksmartbox.com | 01684 578868

thinksmartbox.com

email repairs@thinksmartbox.com
tel 01684 578868
fax 01684 897753

